

# Mobile manipulator

Luca Silvagni

*Business Development Manager*



## AI - Driven

### Per il kitting Intelligente

**Il nostro brand specializzato  
per soluzioni di cobotica:**

**kassow robots**

strong · fast · simple



**rexroth**  
A Bosch Company

# Mobile Manipulator AI-Driven Partner coinvolti



**REPLY**  
ROBOVERSE



**JOYTEK**



# Mobile Manipulator AI-Driven

## Descrizione del progetto

Sviluppo di una piattaforma robotica mobile e collaborativa, guidato da **Intelligenza Artificiale** e **Computer Vision**

Componenti base **Bosch Rexroth**

kassow robots  
strong · fast · simple

Joining forces with

rexroth  
A Bosch Company



ctrlX | rexroth  
AUTOMATION | A Bosch Company

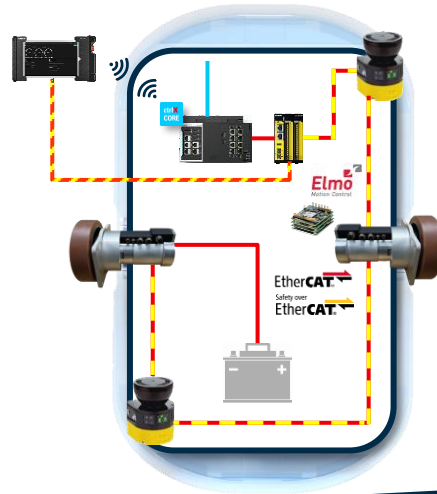

# Mobile Manipulator AI-Driven

## Descrizione del progetto

Sviluppo di una piattaforma robotica mobile e collaborativa, guidato da **Intelligenza Artificiale** e **Computer Vision**

Componenti base **Bosch Rexroth**

kassow robots  
strong · fast · simple

Joining forces with

rexroth  
A Bosch Company

# EDGE Edition



# Mobile Manipulator AI-Driven Architettura logica e SW

Sistema Operativo: **ctrlX OS** su **CtrlX CORE+** Ubuntu Core su Nvidia PC con Master ROS 2

**Architettura distribuita:** ogni componente è un nodo ROS 2

Sistema navigation/localization **Bosch Rexroth Rokit:**

- Tecnologia **SLAM** / static map
- Real-time **obstacle avoidance**
- Predisposizione **VDA5050** per interfacciamento a gestore flotta

Safety:

- Funzioni Safety attraverso **PLS** integrati sulla base AMR
- Arresto di emergenza e limiti dinamici in accord con norme **ISO 3691-4 / ISO 10218-1**

Sensori:

- 2 × **Camere al polso** (Robotiq gripper camera)
- 1 × Camera centrale stereo (**Intel RealSense**)
- 2 × **PLS** per creare la mappa di navigazione

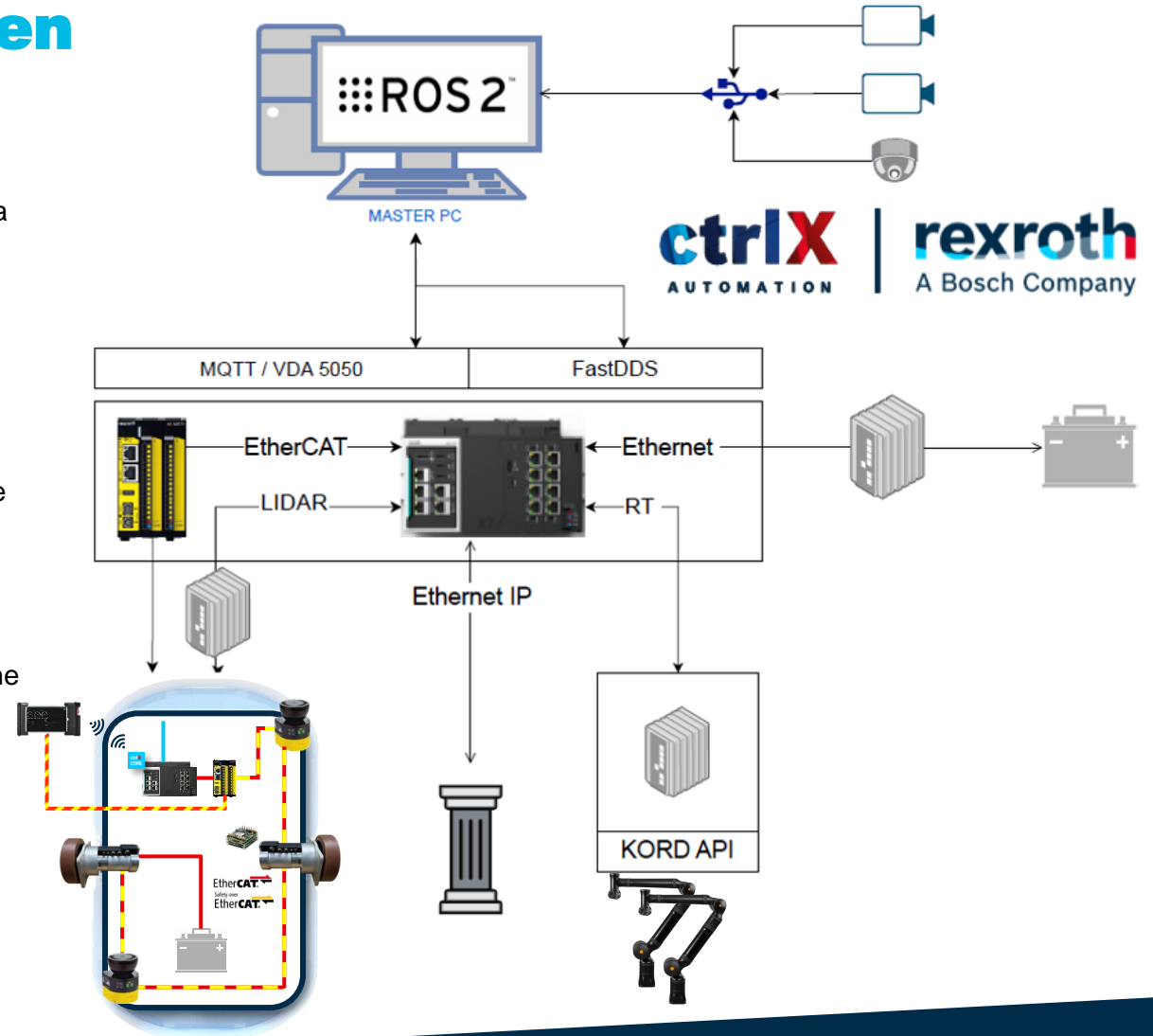

# Mobile Manipulator AI-Driven AI e Simulazione

Utilizzo di tecniche **Imitation** e **Reinforcement Learning** per la manipolazione avanzata

**Computer Vision** customizzata ad alte performance per la manipolazione

Digital Twin sviluppato su simulatore **Isaac Sim** della suite **NVIDIA Omniverse**



# Mobile Manipulator AI-Driven Video



# Mobile Manipulator AI-Driven

## Altre applicazioni

**Asservimento materiali su  
magazzini di macchine automatiche  
e linee di produzione**

Carico/scarico bobine

Carton Loading

Pallettizzatore mobile

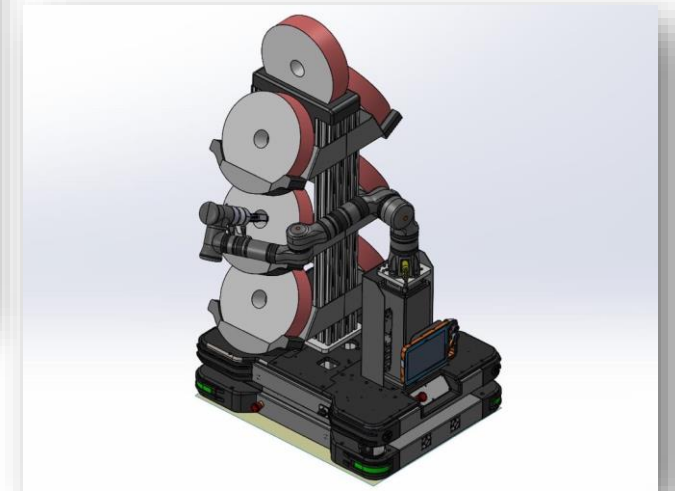
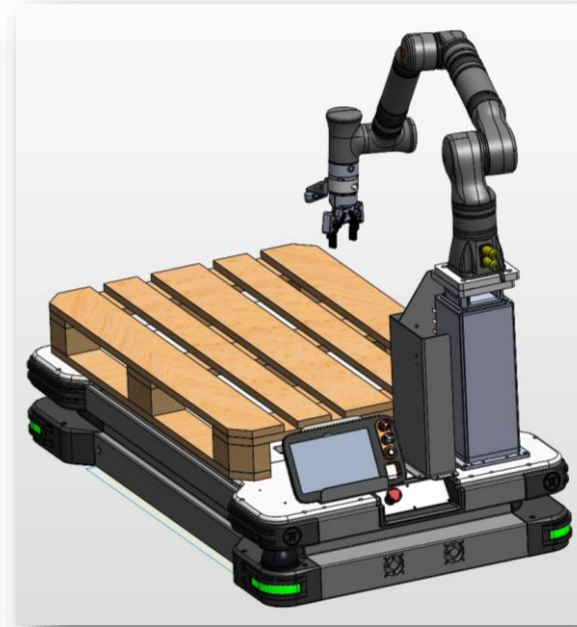



**Luca Silvagni**

*Business Development Manager*

*luca.silvagni@boschrexroth.it*

*+39 349 9308076*



**Be Brave, Have Fun.**

Factory Automation

**rexroth**  
A Bosch Company